

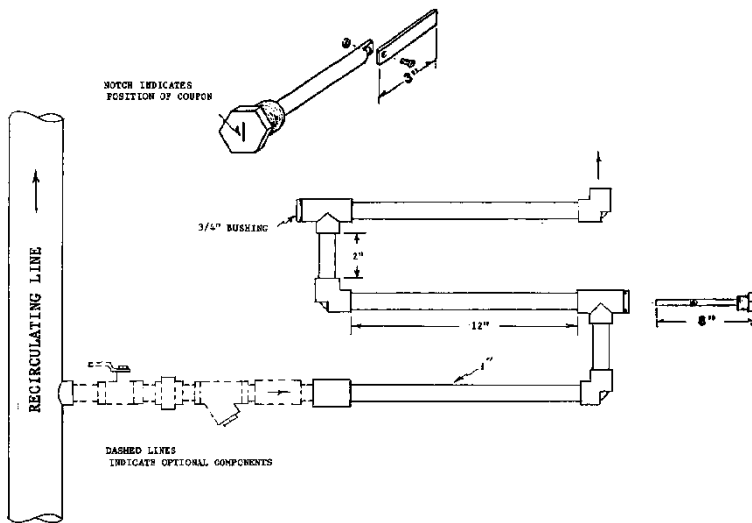

Corrosion Monitoring

WHY SHOULD I USE A CORROSION RACK?



The Corrosion Rack illustrated here is a piping installation for water flow that is designed to be used for corrosion measurement. The right angle turns of this rack are designed to insert corrosion coupon holders. These holders ordinarily consist of steel or other threaded plugs with a Teflon® holder. To the end of this holder, a Corrosion Coupon is attached using a Teflon® screw and nut combination. A flow restricting orifice or flow rate indicator is used to simulate a critical flow rate.

Corrosion Coupons are pre-weighed strips of steel, copper or other metals which are used to measure corrosion in various water systems.

These Corrosion Coupons are exposed to the flow of Cooling Tower water or other waters for a period of 60-90 days. They are returned to our Independent Laboratory where they are cleaned and re-weighed. The weight loss is converted to a mils per year of metal loss from corrosion.

- *In other words, we predict how many thousandths of an inch can be expected to be lost on these metals in a one year period of time due to the corrosive conditions within the system.*

This method is a very valuable tool for evaluating the effectiveness of the corrosion inhibitor being introduced into the system. If the corrosion rate is excessive, steps should be taken to reduce the corrosion rate. This can include:

- A change in the corrosion inhibitor;
- An increase in the dosage of the corrosion inhibitor.

Often, other factors are considered. Among these are:

- The extent to which microbiologically-induced corrosion is a factor;
- Whether under-deposit corrosion has occurred.

For a Cooling Tower, the water that should be circulated through the Corrosion Rack is the hot return water, often called the "hot riser" water.

Corrosion Monitoring (cont'd)

Corrosion Racks are also very useful in the evaluation of treated Closed Systems, including Hot Water Boilers and Chilled Waters. They can also be used on condensate return water for corrosion measurement, but a live steam sample should be condensed with a sample cooler prior to introduction into the Corrosion Rack. Installing a Corrosion Rack to avoid the loss of this condensate takes special care and consideration, so please contact your Bond Water Technologies Representative to discuss.

Corrosion Racks are available from Bond Water Technologies and are available in ¾" or 1" PVC or Black Iron, for High Temperature applications, and come in 2, 3 and 4 pass configurations. The Coupon Holders and installation advice are readily available from your Bond Water Technologies Representative. With multi-position racks, coupons are replaced on a rotating basis so that a timeline observance of corrosion rates can be observed. For example, after installing two coupons, remove one after 60 days and replace it with a new coupon. Remove the second coupon after another 60 days. Continuing this cycle gives you a 60 day corrosion report every 30 days.

Bond provides the Corrosion Coupons and the related testing and reporting as a service to its customers. As a guideline for mild steel, the following corrosion rates can be interpreted as follows:

- √ 0-2 mils per year - Excellent corrosion control.
- √ 2-3 mils per year - Generally acceptable for all systems.
- √ 3-5 mils per year - Fair corrosion control.
- √ Above 5 mils per year - Unacceptable corrosion control.

(NOTE: SEE CORROSION RATE TABLES ON PAGE 3 FOR MORE DEFINITIVE MEASUREMENTS)

At times, you may want to look at two different metals. In this case it would be best to use a 4-position rack with two steel and two copper coupons for example. Always place mild steel ahead of copper coupons in the path of flow. The direction of flow in all Corrosion Racks should always be over the Coupon Holder then over the coupon. Water flow should never be directed towards the end of the coupon.

For additional information on this and other subjects related to Cooling Tower or Boiler Water treatment, please contact your local Bond Water Technologies Representative @ 301-721-BOND (2663)

STANDARDS for CORROSION RATES

The following acceptable Corrosion Rates for Carbon Steel and Copper alloys in Open Recirculating Cooling Water Systems are listed in **Table 1**. Corrosion rates for Hot and Chilled Closed Loop Systems are listed in **Table 2**. The recommended time frame using coupons placed into a corrosion test rack is approximately 90 days, minimum. In an Open Cooling Water System 90 – 120 days exposure time is acceptable and in a Closed Loop System 90 – 365 days is expectable. Either systems must be in operation, with water flow at all times (no prolonged stagnant down time), in order for the corrosion rate study to be meaningful. Any corrosion rate in the Poor or Very Poor to Severe range should be investigated and adjustments made to the Water Treatment Program to correct, ASAP.

Table 1

Quantitative Classification of Corrosion Rates for Open Recirculating Cooling Water Systems

Corrosion Rates (mpy)

Description	Carbon Steel	Copper Alloys
Excellent	0.0 – 1.0	0.0 – 0.1
Mild or Very Good	1 - 3	0.1 – 0.25
Good	3 – 5	0.25 – 0.35
Moderate to Fair	5 – 8	0.35 – 0.5
Poor	8 – 10	0.5 – 1.0
Very Poor to Severe	> 10	> 1.0

Table 2

Quantitative Classification of Corrosion Rates for Hot/Chilled Closed Loop Water Systems

Corrosion Rates (mpy)

Description	Carbon Steel	Copper Alloys
Excellent	0.0 – 0.2	0.0 – 0.1
Mild or Very Good	0.2 – 0.5	0.1 – 0.25
Good	0.5 – 0.8	0.25 – 0.35
Moderate	0.8 – 1.0	0.35 – 0.5
Poor to Severe	>1.0	> 0.5